

# ANTAM STANDARD CODE FOR TESTING OF POWER TILLERS

001-2018

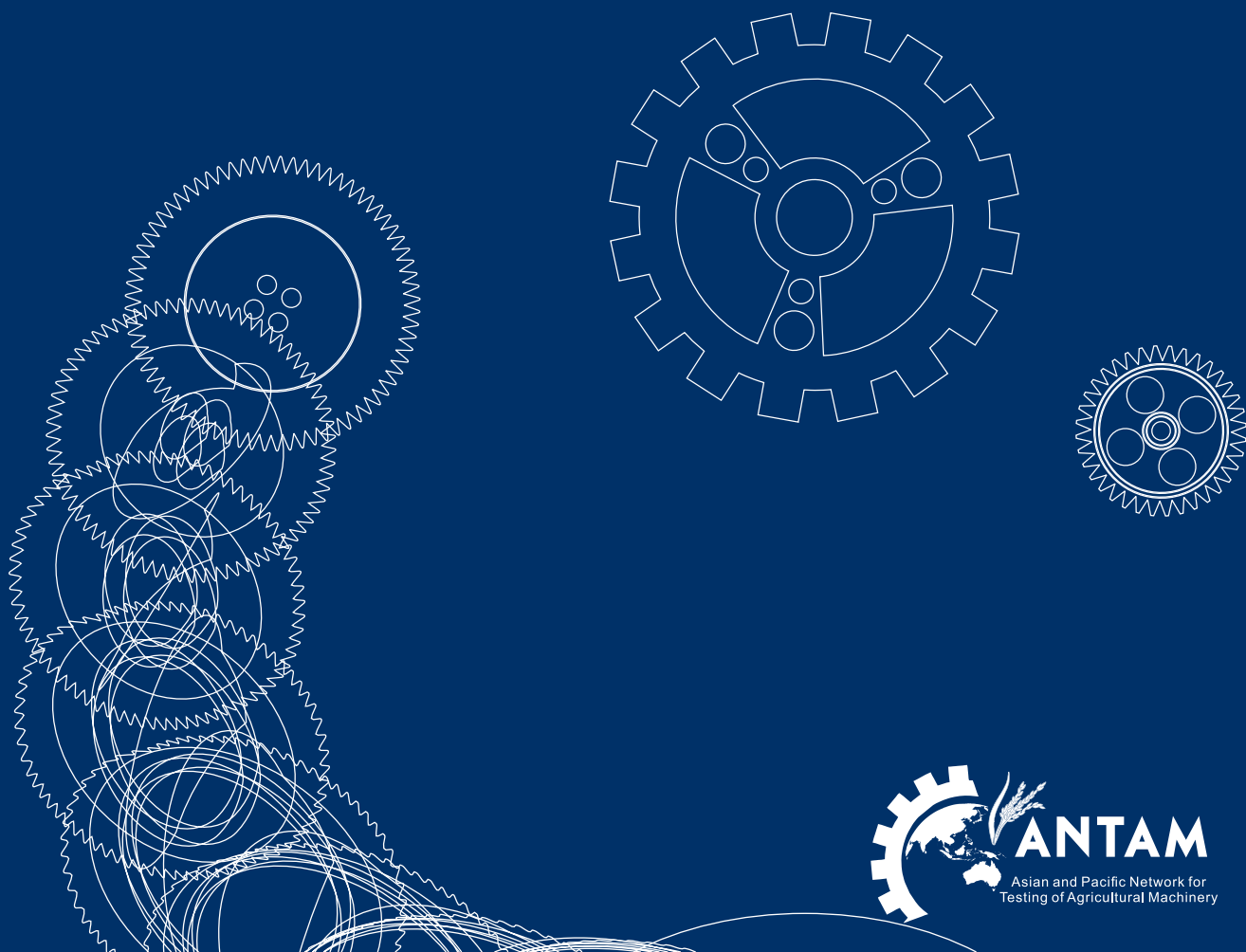

The Centre for Sustainable Agricultural Mechanization (CSAM), is a regional institution of the United Nations Economic and Social Commission for Asia and the Pacific (ESCAP), based in Beijing, China. CSAM started operations in 2004, building on the achievements of the Regional Network for Agricultural Machinery (RNAM) and the United Nations Asian and Pacific Centre for Agricultural Engineering and Machinery (UNAPCAEM). CSAM serves the 62 members and associate members of ESCAP.

The vision of CSAM is to achieve production gains, improved rural livelihood and poverty alleviation through sustainable agricultural mechanization for a more resilient, inclusive and sustainable Asia and the Pacific.

The Secretariat of the Asian and Pacific Network for Testing of Agricultural Machinery (ANTAM) is based at CSAM. CSAM is the executing agency of ANTAM. The ANTAM Secretariat assists and coordinates the operation of the network, and provides necessary logistical and administrative support.

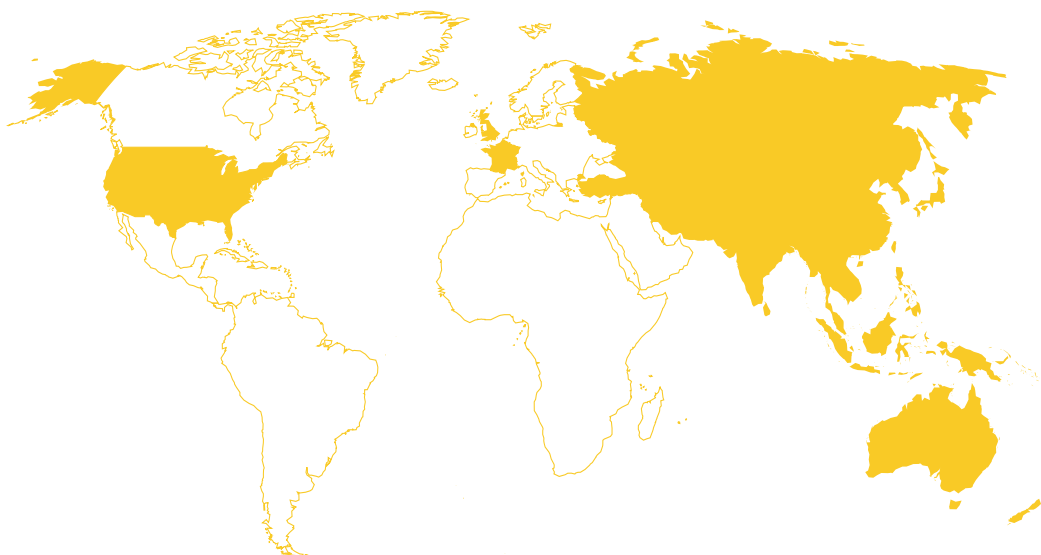

The shaded areas of the map indicate ESCAP members and associate members

The designations used and the presentation of the material in this publication do not imply the expression of any opinion on the part of the ESCAP Secretariat concerning the delimitation of its frontiers or boundaries. Any mention of firm names and commercial products do not imply the endorsement of ESCAP/CSAM.

# **ANTAM STANDARD CODE FOR TESTING OF POWER TILLERS**

**Centre for Sustainable Agricultural Mechanization  
United Nations Economic and Social Commission for Asia and the Pacific**

**001-2018\***

**September 2018**

\* Subject to adoption by the 5<sup>th</sup> Annual Meeting of ANTAM to be held in November 2018

Copyright © 2018 United Nations. All rights reserved.

The Centre for Sustainable Agricultural Mechanization of the United Nations Economic and Social Commission for Asia and the Pacific (CSAM-ESCAP) encourages the use and dissemination of ANTAM Test Codes provided that appropriate acknowledgement of ESCAP as the source and copyright holder is given. Reproduction of the material for resale or other commercial purposes is prohibited without written permission of the copyright holder. All requests should be addressed to [info@un-csam.org](mailto:info@un-csam.org).

## Acknowledgments

The Asian and Pacific Network for Testing of Agricultural Machinery (ANTAM) Standard Code for Testing of Power Tillers was prepared under the supervision of the Centre for Sustainable Agricultural Mechanization of the United Nations Economic and Social Commission for Asia and the Pacific (CSAM-ESCAP). The current version of the Code is based on the first edition published in August 2015 and modified based on technical negotiations conducted with designated national counterparts from 2015 to 2018.

The consultation process in 2018 started in March and was concluded at the 4th Meeting of the Technical Working Groups (TWGs) of the Asian and Pacific Network for Testing of Agricultural Machinery (ANTAM) held on June 25-28, 2018 in Georgetown, Penang, Malaysia. The Code has been developed with contributions from: Israil Hossain; Chhoeur Sothunn; Chang Xiongbo; Champat Raj Mehta; Muhamad Iqbal, Joko Pitoyo; Takahashi Hiroyuki; Mohd Khusairy Khadzir; Darwin Aranguren; Vadim Pronin; Pavel Ishikin; Janaka Hemachandra; Anuchit Chamsing; and Le Huy Phuong. The ANTAM Test Code on Power Tillers was formulated by referring to standards developed by the International Electrotechnical Commission (IEC), International Organization for Standardization (ISO), and Organisation for Economic Co-operation and Development (OECD), and by merging relevant national standards from China, and India to reflect unique regional conditions.

Special thanks go to the ANTAM Focal Points in the Philippines, Malaysia and China, namely Dr. Aurelio Delos Reyes Jr., Mr. Mohd Taufik Bin Ahmad and Ms. Han Xue, for the important support provided during the organization of ANTAM meetings in their respective countries.

The contribution of the Italian Agency for Agricultural Mechanization (ENAMA), the Technical Reference Unit of ANTAM, which has provided technical peer review and guidance to the overall development of ANTAM, is gratefully acknowledged. A note of appreciation is also due to other collaborating partners of ANTAM, including the Food and Agriculture Organization of the United Nations, OECD, the United Nations Industrial Development Organization and all ANTAM Focal Points (Appendix 1) in member countries for their continuous support to and active involvement in ANTAM.

At CSAM, the process of development of the Code was coordinated by Camilla Stelitano under the supervision of Anshuman Varma, Programme Officer and the overall guidance of Li Yutong, Head of CSAM. Dr. Singh Surendra provided final reviews and editing of the Code and Mr. Wei Zhen contributed to the layout and design of the publication.

Foreword .....	6
Method of Operation .....	7
<b>TESTING OF POWER TILLERS .....</b>	<b>8</b>
1. SCOPE .....	8
2. REFERENCES .....	8
3. TERMINOLOGY .....	8
3.1 Power Tiller .....	8
3.2 Maximum Engine Power .....	9
3.3 Operational Mass .....	9
3.4 Rated Engine Power .....	9
3.5 Tyre Rolling Radius .....	9
3.6 Wheel Slip .....	9
4. GENERAL GUIDELINES .....	9
4.1 Conditions for Checking of Dimensions .....	9
4.2 Running-in .....	10
4.3 Servicing and Preliminary Setting after Running-in .....	10
4.4 Ballasting .....	10
4.5 Repairs and Adjustments During Tests .....	11
4.6 Fuels and Lubricants .....	11
4.7 Auxiliary Equipment .....	11
4.8 Fuel Consumption .....	11
4.9 Atmospheric Conditions .....	11
5. MEASURING TOLERANCES .....	12
6. TESTS .....	13
7. CHECKING OF SPECIFICATIONS .....	13
7.1 Specification Sheet .....	13
7.2 Conditions for Checking of Dimensions .....	13
8. ENGINE TEST .....	13
8.1 General .....	13
8.2 Natural Ambient Test .....	14
8.3 High Ambient Test (Optional) .....	15
9. ROTARY SHAFT TEST .....	16
9.1 General .....	16
9.2 Natural Ambient Temperature Test .....	16
10. DRAWBAR TEST .....	17
10.1 General .....	17
10.2 Test for Maximum Power and Pull .....	18
11. TURNING ABILITY TEST .....	18

11.1 General .....	18
11.2 Procedure.....	19
12. PARKING BRAKE TEST .....	19
12.1 General .....	19
12.2 Procedure.....	20
13. NOISE TEST.....	20
13.1 General .....	20
13.2 Measurement at By-stander Position.....	20
13.3 Measurement at Operator Ear Level .....	21
14. VIBRATION TEST .....	21
15. WATERPROOF TEST .....	21
15.1 General .....	21
15.2 Test Conditions .....	22
15.3 Test Procedures .....	22
16. SAFETY REQUIREMENTS .....	23
16.1 Guards .....	23
16.2 Controls .....	23
16.3 Working Stability .....	23
16.4 Lighting .....	23
16.5 Power Transmission .....	23
16.6 Other Requirements.....	23
16.7 Operational Safety Requirements.....	24
ANNEX A: LIST OF CITED STANDARDS.....	25
ANNEX B: PROFORMA FOR SELECTION, RUNNING-IN AND REPAIRS .....	26
ANNEX C: SPECIFICATION SHEET FOR POWER TILLERS .....	27
ANNEX D: DATA SHEET FOR LABORATORY AND TRACK TESTS OF POWER TILLER .....	31
ANNEX E: PROFORMA FOR SAFETY CHECK.....	40
Appendix I ANTAM Focal Points .....	41
Appendix II: ANTAM Technical Working Groups Members 2018.....	45

## Foreword

The Asian and Pacific Network for Testing of Agricultural Machinery (ANTAM) is an initiative led by the Centre for Sustainable Agricultural Mechanization (CSAM) of the United Nations Economic and Social Commission for Asia and the Pacific (ESCAP). In support of the 2030 Agenda for Sustainable Development, the ANTAM network develops regional standards to promote the use of safe, efficient and environmentally sound agricultural machinery in the Asia-Pacific region.

The 2030 Agenda for Sustainable Development recognizes eradicating poverty in all its forms as the greatest human challenge. The 17 Sustainable Development Goals (SDGs) advocate for multisectoral, coordinated action to integrate the three dimensions of sustainable development: the economic, social and environmental. Eradicating poverty (SDG 1) and hunger (SDG 2) occupy central stage in the work of ESCAP-CSAM. The important contribution of mechanization to agricultural productivity has long been recognized by experts<sup>1</sup>. Nevertheless, the factors that influence the diffusion of mechanization, in particular for developing and least developed countries, involve multiple sub-sectors such as farmers' access to capital, infrastructure development, manufacturing capacity and import regulations. To tackle this complex and interconnected set of issues the public sector can play a crucial role by implementing regulations that, in a time and cost-effective manner, assist stakeholders in overcoming economic and other practical impediments to the diffusion of mechanized agriculture. Testing and certification of agricultural machinery is recognized as one of the most effective public interventions in support of the diffusion of mechanization<sup>2</sup>.

The certification released after testing is a written assurance for farmers, retailers, importers and manufacturers that testifies to the stated specifications of a given machine. This aspect is particularly important because according to several experts<sup>3</sup>, the constraints in the introduction, use and export of agricultural machinery can be attributed to lack of quality, design, and production techniques. Since the quality of the same type of machine manufactured by different firms can vary greatly, farmers are reluctant to invest in unknown technology without assurance of quality or efficiency. The variations in quality amongst the same type of machinery can be minimized by following standard design and production techniques. In addition, the presence of a recognized certification, issued after testing, can help farmers in determining the comparative performance of machines available in the market and the public sector as well as financial institutions in allocating financial support for the purchase of reliable equipment.

Agricultural machinery testing Codes are among the key elements of a well-functioning certification system. The ANTAM Codes for testing of agricultural machinery draw upon national standards of ESCAP member States and major international requirements for agricultural machinery testing. They aim to help our stakeholders in identifying sustainable, affordable and environmentally sound machinery. The fourth version of the ANTAM Codes that we are presenting in 2018, builds upon the work conducted since 2015 and incorporates important feedback received from our member States to integrate their needs into one standard able to serve the unique agricultural characteristics of countries in the Asia-Pacific region.

Li Yutong  
Head

Centre for Sustainable Agricultural Mechanization

---

<sup>1</sup> FAO (2013) *Mechanization for Rural Development: A review of patterns and progress from around the world- Integrated Crop Management Vol. 20-2013*; Plant Production and Protection Division of the Food and Agriculture Organization of the United Nations; Rome, Italy.

<sup>2</sup> World Bank (2017) *Enabling the Business of Agriculture 2017*; Washington, DC, World Bank.

<sup>3</sup> Mehta M L; Verma S R; Misra S K; Sharma V K. 2016. *Testing and Evaluation of Agricultural Machinery*. Vedams eBooks [P] Ltd. New Delhi



## Method of Operation<sup>4</sup>

The Annual Meeting shall adopt the Test Codes by consensus amongst ANTAM participating countries.

The Technical Working Groups (TWGs) of ANTAM develop, review and revise ANTAM Codes based on the decisions adopted at the Annual Meeting of ANTAM.

The ANTAM Test Codes are updated by the TWGs through technical negotiations led by CSAM. The content of the Codes is finalized and agreed upon by consensus amongst all TWGs members at the annual meetings of the TWGs.

The ANTAM Test Code on Power Tillers was formulated by referring to relevant International Electrotechnical Commission (IEC), International Organization for Standardization (ISO), and Organisation for Economic Co-operation and Development (OECD) standards and merging relevant national standards from China and India. As specified in the Terms of Reference of the TWGs, members are responsible for selecting and providing relevant references to national and international standards. All selected standards are subject to revision and considered the most updated edition as per documents provided by TWGs members. All documents provided by national standards agencies are copyrighted.

Implementation of ANTAM Test Codes is voluntary. Member countries can use ANTAM Test Codes in their entirety or refer to parts of the Code to integrate them with procedures applied in national testing stations. ANTAM Test Codes apply only to the equipment described in the Codes. Thus, any testing station from an ANTAM member country is welcome to use the test Codes assuming it has adapted testing equipment, facilities and skilled personnel as necessary.

Participating national testing stations are responsible for using the Codes to carry out the tests and complete the test report. Each testing station shall certify that ANTAM Codes are followed and that the test report complies with ANTAM Test Codes and procedures. ANTAM strongly encourages the implementation of round robin tests<sup>5</sup> among testing stations in order to ensure that test reports are supported by a quality assurance process.

The test report shall be verified by the ANTAM Secretariat prior to its release. The ANTAM Secretariat shall work with the Technical Reference Unit (TRU), an independent third party elected by member countries at the Annual Meeting, to check the technical contents of the report to ensure strict compliance with ANTAM testing methodologies.

Upon approval and validation of the test report by the ANTAM Secretariat, the ANTAM logo may be used on the tested machinery. The ANTAM Secretariat will then release the test report on its website.

The ANTAM Test Codes are designed to guide member countries in the application of standards for testing of agricultural machinery. The Codes provide information only and do not constitute formal legal advice. The ANTAM Secretariat assumes no liability for actions undertaken in reliance on the information contained in the Codes.

---

<sup>4</sup> In reference to the Terms of Reference of ANTAM and the Terms of Reference of ANTAM Technical Working Groups adopted by the Annual Meeting on December 9, 2016.

<sup>5</sup> Measurement system analysis technique, where independent technicians perform the tests in different stations. Such interlaboratory activity is encouraged to compare discrepancies in results, if any, and determine the reproducibility of test methods.

\* The current Code is subject to revision and adoption by the 5<sup>th</sup> Annual Meeting of ANTAM to be held in Indonesia in November 2018.

# TESTING OF POWER TILLERS

## 1. SCOPE

This Test Code covers the terminology, general guidelines and tests to be conducted on power tillers with diesel engine excluding mini tillers. It also covers methodology for checking of machine specifications, engine performance, rotary shaft performance, vibration level, drawbar performance, turning ability, parking brake ability, noise measurement, waterproof ability and safety requirements.

The tests are conducted for establishing performance characteristics of power tillers that are ready for commercial production or already in production. The manufacturer must specify whether the test is confidential or for commercial purpose.

This publication supersedes the previous ANTAM Standard Code for testing of Power Tillers (ANTAM 001-2017).

## 2. REFERENCES

The complete list of references to existing international standards that have been incorporated to this text is provided in **Annex A**. The list includes international standards developed by the International Organization for Standardization (ISO), Organisation for Economic Co-operation and Development (OECD) and national standards practiced by China and India. The selection of publications and the editions indicated were provided by the respective national representatives. All selected standards are considered recent as per documents provided. All documents provided from national standards agencies are copyrighted.

## 3. TERMINOLOGY

### 3.1 Power Tiller

Power tiller is a self-propelled agricultural machinery used for field operations (tilling, seeding, plant protection, harvesting etc.) and haulage having a single axle, in which the direction of travel and its control are performed by the operator. The machine may be walk behind or riding type. The maximum speed of the power tiller when coupled to a trailer shall not exceed 22 km/h (IS 13539: 2008). The rated power output of the power tiller engine shall be in the range from 6 kW to 13.5 kW.

#### 3.1.1 General Purpose Type

The power tiller which can be used for several farm operations, including the types defined under pull type and tilling type.

##### 3.1.1.1 Pull Type

The power tiller which pulls various kind of implements.

##### 3.1.1.2 Tilling Type

The power tiller which uses an engine power driven tilling device such as rotary and crank or screw blades.

### 3.2 Maximum Engine Power

Maximum sustainable engine power available at the crankshaft.

### 3.3 Operational Mass

The mass of the power tiller without operator in normal working condition with fuel tank and radiator (if fitted) full and lubricants filled to the specified levels.

Note: Any accessory fitted and its mass should be stated.

### 3.4 Rated Engine Power

The power available at the crankshaft or its equivalent at the rated speed specified by the manufacturer.

### 3.5 Tyre Rolling Radius

The effective tyre rolling radius is the average distance travelled by the power tiller in one rotation of the driving wheels divided by  $2\pi$ , when the power tiller is driven without drawbar load at a speed of approximately 2 km/h. The mass of operator shall be reported when the power tiller is tested with operator seat.

### 3.6 Wheel Slip

This shall be determined by the following formula:

$$\text{Slip, percent} = \frac{100 (N_1 - N_2)}{N_1}$$

Where

$N_1$  = Sum of revolutions of driving wheels for a given distance (at least 20 m) when the power tiller is driven under load, and

$N_2$  = Sum of revolutions of driving wheels for the same distance when the power tiller is driven without load at a speed approximately 2.0 km/h

## 4. GENERAL GUIDELINES

### 4.1 Conditions for Checking of Dimensions

**4.1.1** The power tiller shall be without ballast, any wear on tyres and placed on a firm horizontal surface (4.2.1 IS 9935-2002). The height of the tyre tread bars shall not be less than 65 % of their height when new. The main frame shall be in horizontal position (9.2.6 GB/T 6229-2007).

**4.1.2** Unless otherwise stated by the manufacturer/applicant, the power tiller shall be stationary with its wheels and standard components in the positions they would be, if the power tiller was travelling in a straight line (4.2.2 IS 9935-2002).

**4.1.3** The pressure in pneumatic tyres shall be adjusted to the value recommended by the power tiller manufacturer for field work (4.2.3 IS 9935-2002). If a range of value is indicated the mean tyre pressure shall be used (3.3.3 GB/T 6229-2007).

## **4.2 Running-in**

The manufacturer/applicant shall run-in the power tiller before the test, under his responsibility and in accordance with his usual instructions. The running-in shall be carried out in collaboration with the testing authority. If this procedure is impracticable due to the power tiller being an imported model, the testing authority may run-in the power tiller in accordance with the procedure prescribed or agreed to with the manufacturer/applicant.

The place and duration of the running-in shall be reported in the proforma given in **Annex B**.

## **4.3 Servicing and Preliminary Setting after Running-in**

**4.3.1** After completion of running-in, servicing and preliminary settings should be done according to the printed literature supplied by the manufacturer/applicant. The following may be carried out, wherever applicable:

- a) Change of the engine oil;
- b) Change of air cleaner oil (if provided with an oil bath type air cleaner);
- c) Change of transmission oil;
- d) Change of oil and fuel filters (if required);
- e) Greasing/oiling of all the lubricating points;
- f) Adjustment of valve clearance and injection pressure (if required);
- g) Tightening the nuts and bolts;
- h) Checking and adjusting the tension of belts and chains;
- i) Checking and adjustment of safety devices, if any;
- j) Any other checking or adjustment recommended by the manufacturer after the running-in period, and included in the printed literature of the power tiller.

**4.3.2** The manufacturer/applicant may adjust fuel injection pump, governor and fuel injector during the period the power tiller is prepared for tests. These adjustments should conform to the values specified by the manufacturer/applicant for agricultural use in the printed literature/specification sheet. No other adjustment shall be made, unless it is recommended in the literature. All the parts replaced shall be reported in the test report.

Note: Adjustment of fuel injection pumps except for low/high idling speed shall not be permitted under test.

## **4.4 Ballasting**

The ballast mass, which are commercially available and approved by the manufacturer for use in agriculture, shall be within the limits specified by the manufacturer or load limit of axle. For wheeled power tillers, inflation pressure and ballast on each tyre shall be within the limits specified by the tyre manufacturer or load limit of axle, whichever is lower. Measure inflation pressure with the tyre/tube valve in the lowest position.

## **4.5 Repairs and Adjustments During Tests**

All repairs and adjustments made during the tests shall be reported, together with comments on any practical defects or shortcomings in **Annex B**. This shall not include those maintenance jobs and adjustments which are performed in conformity with the manufacturer's recommendations.

## **4.6 Fuels and Lubricants**

Fuels and lubricants shall be selected from the range of products commercially available in the country where the equipment is tested and shall conform to the minimum standards approved by the power tiller manufacturer. If the fuel or lubricant conforms to a national or international standard, it shall be mentioned and the standard stated (OECD Code 2-2017).

## **4.7 Auxiliary Equipment**

For all power tests, accessories/auxiliary drives (if any) may be disconnected only if it is practicable to do so as a normal practice during work in accordance with the operator's manual without using any tool. If not, they shall remain connected and operate at minimum load.

## **4.8 Fuel Consumption**

The fuel measurement apparatus shall be so arranged that the fuel pressure at the fuel transfer pump is equivalent to that which exists when the power tiller fuel tank is half full. The fuel temperature shall be comparable to that in the normal operation of the power tiller when fuel is taken from the fuel tank of power tiller.

**4.8.1** To obtain hourly fuel consumption by volume and the work performed per unit volume of fuel, conversion of unit of mass to unit of volume shall be made using the density value at 15°C (IS 9935:2002).

**4.8.2** When the fuel consumption is measured by volume, the specific fuel consumption shall be calculated using the density corresponding to the appropriate fuel temperature.

## **4.9 Atmospheric Conditions**

### **4.9.1 Atmospheric Pressure**

The atmospheric pressure shall not be less than 96.6 kPa during laboratory tests (5.2.3 GB/T 6229-2007). The pressure shall be noted at the start, middle and end of the test.

### **4.9.2 Temperature**

For power tests, the normal ambient temperature shall be  $27 \pm 7^\circ\text{C}$  (5.2.3 GB/T 6229-2007). Ambient air temperature shall be measured approximately 2 m in front or side depending upon the location of suction or blower device of power tiller and approximately 1.5 m above the ground (IS 9935:2002).

Note: No correction shall be made to the test results for atmospheric conditions.

## 5. MEASURING TOLERANCES

The measuring apparatus shall be such that the following items shall have the tolerances within the limits shown against each in Table 1 (4.1.2 GB/T 6229-2007, IS 9935:2002):

Table 1. Accuracy requirements of measurement

<b>Parameters</b>	<b>Tolerances</b>
a) Rotational speeds (rpm)	$\pm 1.0 \%$
b) Time (s)	$\pm 0.2$ s
c) Distance (m or mm)	$\pm 0.5 \%$
d) Force (N) and torque (Nm)	$\pm 1.0 \%$
e) Acceleration ( $m/s^2$ )	$\pm 1.0 \%$
f) Mass (kg)	$\pm 0.5 \%$
g) Atmospheric pressure (kPa)	$\pm 0.2$ kPa
h) Tyre pressure (kPa)	$\pm 5 \%$
i) Temperature of fuels etc. ( $^{\circ}C$ )	$\pm 2^{\circ}C$
j) Wet and dry bulb temperatures ( $^{\circ}C$ )	$\pm 0.5^{\circ}C$
k) Fuel consumption (overall for the apparatus used): 1) Engine test (kg) 2) Rotary shaft test (kg) 3) Drawbar test (kg)	$\pm 1.0 \%$ $\pm 1.0 \%$ $\pm 2.0 \%$
l) Angle ( $^{\circ}$ )	$\pm 0.5^{\circ}$

## 6. TESTS

Tests to be conducted on a power tiller are given below:

### *Compulsory tests:*

- Checking of specifications
- Engine performance
- Rotary shaft performance
- Drawbar performance
- Turning ability
- Parking brake
- Noise measurement
- Vibration measurement
- Waterproofing
- Safety check

### *Optional test:*

- Engine test at high ambient temperature.

## 7. CHECKING OF SPECIFICATIONS

### 7.1 Specification Sheet

**7.1.1** The power tiller manufacturer/applicant shall supply the specifications of the power tiller consisting of the items listed in the specimen report given in **Annex C**, as well as any other information required by the testing authority to carry out the tests. The manufacturer/applicant shall also supply technical literature such as operation, maintenance and service manuals, and parts catalogue (4.1 IS 9935: 2002).

**7.1.2** The information given by the manufacturer/applicant in the specification sheet shall be verified by the testing authority and reported. Details of the components and assemblies which do not conform to the relevant ANTAM Code shall also be reported. The adequacy or otherwise of the literature shall be indicated (7.1 IS 9935: 2002).

### 7.2 Conditions for Checking of Dimensions

**7.2.1** While checking the dimensions of the power tiller, the conditions laid down in 4.1 of the general guidelines shall be followed.

## 8. ENGINE TEST

### 8.1 General

The various tests shall normally be carried out continuously.

The angle of the connection of the shaft connecting the crankshaft to the dynamometer shall not exceed 2° (5.2.2 GB/T 6229-2007).

If an exhaust gas discharge device for the test area is used, it shall not change the engine performance.

The governor control shall be set for maximum power.

## 8.2 Natural Ambient Test

Make no corrections to the measured values of torque or power for atmospheric conditions or other factors. The atmospheric pressure shall not be less than 96.6 kPa. If this is not possible because of altitude, a modified fuel pump setting may be used, the details of which shall be included in the report. The surrounding temperature shall be  $27 \pm 7^\circ \text{C}$  (5.2.3 GB/T 6229-2007).

The following tests shall be conducted on the engine:

### 8.2.1 Maximum Power Test

Operate the engine at the speed where maximum power occurs for a period of two hours subsequent to a warming-up period to reach stabilized running conditions. Measure the power, torque and fuel consumption (6.1.2 IS 12036: 1995 and 5.3.1 GB/T 6229-2007).

The maximum power quoted in the test report shall be the average of at least 6 readings made at regular intervals during two-hour period. If the power varies by more than  $\pm 2\%$  from the average, repeat the test. If the variation continues, report the deviation (5.3.1 GB/T 6229-2007).

### 8.2.2 Power at Rated Engine Speed

If maximum power does not occur at rated engine speed, an additional one hour test shall be carried out using the procedure stated in 8.2.1.

### 8.2.3 Varying Speed Test at Full Load

Measure the power, torque and fuel consumption as a function of speed at full load. Minimum 6 readings shall be taken between rated rpm and speed at maximum torque. The minimum speed at which measurements are made shall be the speed at maximum torque and, if possible, 15 % below that speed (6.1.3 IS 12036: 1995 and 5.3.2 GB/T 6229-2007).

### 8.2.4 Varying Load Tests

Measure the power, speed and fuel consumption at the torque values given below with the governor control set for maximum power at the rated engine speed (5.3.3 GB/T 6229-2007).

- a) The torque corresponding to maximum power available at rated engine speed;
- b) 85 % of the torque obtained in (a);
- c) 75 % of the torque obtained in (b);
- d) 50 % of the torque obtained in (b);
- e) 25 % of the torque obtained in (b);
- f) Unloaded [with the dynamometer disconnected if the residual torque is greater than 5 % of the torque defined in (b)].

### 8.2.5 Five Hours Engine Rating Test

The engine shall be run continuously for 5 hours. For the first 4 hours, the engine shall be run at 90% of load (torque) corresponding to maximum power (IS 12036: 1995). During the 5<sup>th</sup> hour, the engine shall be run at a load corresponding to maximum power. During the test, all



the parameters specified in 8.2.4 of this standard shall be recorded at every half-an-hour interval during the first 4 hours and after every 15 minutes during the 5<sup>th</sup> hour (6.1.7 IS 12036: 1995).

Report the following:

- Atmospheric pressure as specified in 4.9.1
- Ambient air temperature at a representative point as specified in 4.9.2
- Relative air humidity;
- Air temperature at the engine air intake;
- Maximum coolant temperature (no need to report coolant temperature in case of an air-cooled engine);
- The fuel temperature at the inlet to the injection pump;
- Engine oil temperature;
- Exhaust gas temperature.

### 8.2.6 Presentation of Results

The observed data in 8.2.1 to 8.2.5 shall be reported in tabular form for each test condition (**Annex D-6**). If also presented in graphical form (which is optional), the following, covering the full range of engine speeds tested, shall be included:

- a) Power as a function of speed;
- b) Torque as a function of speed;
- c) Fuel consumption (mass) and specific fuel consumption (mass) as a function of speed;
- d) Specific fuel consumption (mass) as a function of power;
- e) No-load maximum engine speed.

### 8.3 High Ambient Test (Optional)

The following tests on the engine shall be conducted under high ambient temperature ( $43 \pm 2^\circ \text{C}$ ) (IS 9935:2002).

#### 8.3.1 Maximum Power Test

##### 8.3.1.1 Maximum Power Absolute

Operate the power tiller at the engine speed where maximum power occurs for a period of two-hour subsequent to a warming-up period to reach stabilized running conditions. Measure the power, torque, fuel consumption and speed. The maximum power quoted in the test report shall be the average of at least six readings made at regular intervals during two-hour period. If the power varies by more than  $\pm 2\%$  from the average, repeat the test. If the variation continues, report the deviation.

If power tiller is not capable of transmitting the full power of the engine, operate it for two-hour at a power specified by the manufacturer. If possible, a 20 % increase in power shall be applied every 5 minutes for a period of one minute. If the engine cannot develop the 20 % increase in power, carry out the intermittent test at full engine power.

##### 8.3.1.2 Maximum Power at Rated Engine Speed

If maximum power does not occur at rated engine speed, additional one-hour test shall be carried out using the procedure stated in 8.3.1.1.

The coolant and lubricating oil consumption shall be recorded as under:

- a) Coolant consumption (l/kWh)
- b) Lubricating oil (g/kWh)

### **8.3.2 Varying Speed Test at Full Load** (6.1.3 of IS 12036: 1995)

Measure the power, torque and fuel consumption as a function of speed at full load. Minimum 6 readings shall be taken between rated rpm and speed at maximum torque. The minimum speeds at which measurements are made shall be at the speed of maximum torque and, if possible, 15% below that speed (6.1.3 IS 12036: 1995 and 5.3.2 GB/T 6229-2007).

### **8.3.3 Presentation of Results**

The observed data in 8.3.1 to 8.3.2 shall be reported in tabular form for each test condition (**Annex D-6**). If also presented in graphical form (which is optional), the following, covering the full range of engine speeds tested, shall be included:

- a) Power as a function of speed;
- b) Torque as a function of speed;
- c) Fuel consumption (mass) and specific fuel consumption (mass) as a function of speed;
- d) Specific fuel consumption (mass) as a function of power;
- e) No-load maximum engine speed.

## **9. ROTARY SHAFT TEST**

### **9.1 General**

This test is applicable for tilling type power tiller.

The following tests will be conducted on rotary shaft at the lowest rotary shaft speed if there are more than one rotary shaft speeds available.

### **9.2 Natural Ambient Temperature Test**

During the test, the surrounding temperature will be within the range of  $27 \pm 7$  °C

#### **9.2.1 Varying Speed Test**

Measure the power, torque and fuel consumption as a function of speed at full governor at approximately 1-2% speed increments. Readings shall be taken between no load rpm and speed at maximum torque (maximum power, rated power, maximum torque readings shall be taken). The minimum speeds at which measurements are made will be at the speed of maximum torque and, if possible, 15% below that speed (IS 9935:2002).

#### **9.2.2 Five Hour Test at Rated Power of Rotary Shaft**

The rotary shaft shall be run at 90% of load (torque) corresponding to maximum power continuously for 4 hours. During the 5<sup>th</sup> hour, the engine shall be run at a load corresponding to maximum power. During the test, power, torque and fuel consumption shall be reported at every half-an-hour during first 4 hour and after every 15 minutes during the 5<sup>th</sup> hour (IS 9935:2002).

Report the following:

- Atmospheric pressure as specified in 4.9.1
- Ambient air temperature at a representative point as specified in 4.9.2
- Relative air humidity;
- Air temperature at the engine air intake;
- Maximum coolant temperature (no need to report coolant temperature in case of an air-cooled engine);
- The fuel temperature at the inlet to the injection pump;
- Engine oil temperature;
- Exhaust gas temperature.

NOTE - If the engine speed recommended for field tests is different from rated engine speed, then tests at the recommended speed setting shall also be conducted.

The data will be recorded in **Annex D-7**.

## **10. DRAWBAR TEST**

### **10.1 General**

**10.1.1** The power tiller shall be fitted with pneumatic wheels and the test shall be conducted on a clean, horizontal and dry concrete test track containing a minimum number of joints under natural ambient condition.

The test shall be conducted in running state corresponding to the manufacturer's recommendations. During the test, the operator of power tiller shall be sitting at the provided seating arrangement.

**10.1.2** At the beginning of the test, the height of the tread bars of tyres shall not be less than 65% of their height when new. The measurement shall be made at the centre line of the standard tyres (9.2.6 GB/T 6229-2007).

**10.1.3** During the drawbar performance test , the governor control shall be set at maximum power .

**10.1.4** The test shall not be conducted in the gear for which the forward speed exceeds the safety limit of the power tiller.

**10.1.5** The test shall be made at least in the speeds, from one giving a travel speed immediately faster than in the gear in which the greatest maximum power is developed and one immediately slower than the gear setting allowing maximum pull to be developed (4.4.1.7 OECD Code 2-2014).

**10.1.6** During the test, the line of pull shall be maintained horizontal. The height of the drawbar shall remain fixed in relation to the power tiller.

**10.1.7** The measurement of drawbar pull, speed and slip shall be started only after the operational conditions are stabilized.

**10.1.8** The test shall be conducted for at least 20 m run continuously without varying atmospheric or track conditions significantly (9.2.8 GB/T 6229-2007).

## **10.2 Test for Maximum Power and Pull**

The test shall be conducted until the maximum power and pull are found in different forward speed gears. Measurement of engine speed, drawbar pull, fuel consumption, forward speed and wheel slip shall be recorded (9.3.1 GB/T 6229-2007).

The maximum drawbar pull and drawbar power shall be recorded at power tiller wheel slippage only up to 15%. As the no-slip distance will vary according to the degree of wear of the tyres, it will be necessary to check this regularly, particularly before determining maximum drawbar power (9.3.1 GB/T 6229-2007).

If the manufacturer/applicant recommends ballasting of the power tiller, the test shall be conducted both at ballasted and un-ballasted condition of the power tiller and the results shall be reported separately.

The data shall be recorded in **Annex D-3** and **Annex D-8**.

## **11. TURNING ABILITY TEST (GB/T 6229-2007 and IS 9935: 2002)**

### **11.1 General**

**11.1.1** The test area shall be a horizontal compact or paved surface having good tyre adhesion and capable of displaying legible marking.

**11.1.2** The power tiller shall be tested with all liquid reservoirs filled to the specified level but without ballast, mounted implements and any other specified components.

**11.1.3** At the beginning of the test, the height of the tyre tread bars shall not be less than 65% of their height when new. The inflation pressure in the tyres shall be maintained as recommended for the road work by the manufacturer.

**11.1.4** The test shall be conducted with the power tiller without tail wheel at the minimum attainable speed. The measurement of radius of turning circle and turning space are referred in Figure 1.

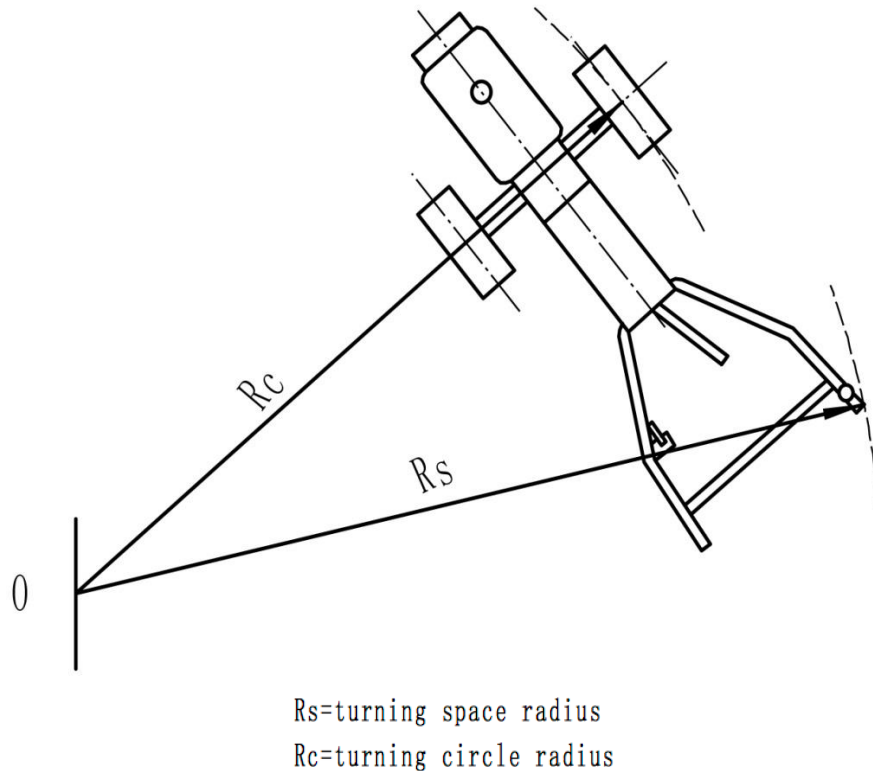

Figure 1: The measurement of radius of turning circle and turning space  
(6.3.1 GB/T 6229-2007)

## 11.2 Procedure

The test shall be carried out, at minimum travel speed of the power tiller by turning it to the right and the left sides using steering clutch until a 360-degree turn is completed. During the test, the following shall be recorded:

- a) Diameter of the minimum turning circle (m), and
- b) Diameter of the minimum turning space required (m).

The data shall be recorded in **Annex D-4**.

## 12. PARKING BRAKE TEST

### 12.1 General

**12.1.1** The performance of the parking brake shall be based on the ability to hold the power tiller stationary, facing up and down on slopes.

**12.1.2** The power tiller without ballast shall be attached with any matching implement e.g. rotary, plough etc.

**12.1.3** The test shall be conducted on a clean, flat and dry concrete test track.

## 12.2 Procedure

**12.2.1** The power tiller shall be placed out of gear on a slope of not less than 18% with the brakes applied. The power tiller shall be placed first facing up and then down the slope, the rotation of the braked wheel shall be observed. The observation along with the factors allowing the rotation of the wheels shall be stated in the test report (IS 9935: 2002).

The force, necessary to apply at the control of the parking braking device to hold the power tiller stationary when facing up and down on slopes shall be measured.

The data shall be recorded in **Annex D-5**.

## 13. NOISE TEST

### 13.1 General

**13.1.1** Sound level meter which meets the requirements of IEC 60651-1979 for a type 1 instrument shall be used.

**13.1.2** The test area shall be a flat open space at least 20 m from the test machine. There shall be no obstacle likely to reflect significant sound, such as building, solid fence, tree or other vehicle.

**13.1.3** The air temperature shall be in the range from -5 to 35 ° C and the wind velocity at 1.2 m above ground level shall not exceed 5 m/s (9.2.4 GB/T 6229-2007).

**13.1.4** The A-weighted sound pressure level of the background noise, including wind noise, shall be at least 10 dB (A) below that produced by the power tiller being tested.

### 13.2 Measurement at By-stander Position (IS 12180-2:2000)

**13.2.1** The noise shall be measured with instrument of A weighted expressed in decibels set on fast level.

**13.2.2** The measurement shall be made with the power tiller stationary on dry concrete surface.

**13.2.3** The engine of the power tiller shall be operating at the maximum speed and all related components shall be functioning as in normal field work. Tillage or moving components shall not engage with the soil or crop.

**13.2.4** The microphone positions shall be located at 7.5 m away from the centerline on each side of the power tiller. The microphone shall be 1.2 m above ground level. The microphone shall be oriented in a direction normal to the centerline of the path of travel of power tiller on the track.

**13.2.5** The octave band sound pressure level may be optionally measured and reported.

**13.2.6** At least 3 measurements shall be made at each position for each operating condition. The reading of the 3 consecutive measurements shall be within 3 dB(A).

The data shall be recorded in **Annex D-9**.

### **13.3 Measurement at Operator Ear Level (IS 12180-1:2000: ISO 5131:1996)**

**13.3.1** The noise measurement test shall be conducted at the operator's ear level during the drawbar pull test.

**13.3.2** The noise shall be measured with instrument of A weighted expressed in decibels set on slow level.

**13.3.3** The test shall be conducted at different drawbar loads in different forward speed gears. The drawbar loads shall be applied by the loading device remotely positioned to eliminate interference with the sound fields caused by the power tiller.

**13.3.4** During the measurement, the microphone shall be horizontal and facing forward. It shall be 50 mm to the side of the operator's forehead and in line with his eyebrows. It shall be mounted on an open frame helmet.

**13.3.5** For seated operators, the microphone shall be located at  $250 \text{ mm} \pm 20 \text{ mm}$  to the side of the center plane of the seat, the side being that on which the higher sound pressure level is encountered. The center of the microphone shall be  $700 \text{ mm} \pm 20 \text{ mm}$  above the seat index point and  $100 \text{ mm} \pm 20 \text{ mm}$  forward of that point. Excessive vibration of the microphone shall be avoided. The seat index point shall be determined in accordance with ISO 5353: 1995.

**13.3.6** The sound level measurements shall be made in all forward speed gears under safety test condition. The results shall be reported in the gear giving the nearest forward speed of 2 km/h and under any gear for which a sound level of at least 1 dB(A) above that of the above-mentioned gear was recorded.

The data shall be recorded in **Annex D-9**.

## **14. VIBRATION TEST**

**14.1** The power tiller shall be parked on a level concrete surface and tyres inflated according to off field pressure recommended for road work. The power tiller and its rotary tiller attachment (if recommended by manufacturer) shall be operated at rated engine speed at no-load (IS 9935:2002).

**14.2** The acceleration of mechanical vibration of components/assemblies of the power tiller shall be measured with the help of suitable vibration measuring device on the components listed in Annex D-8.

The data shall be recorded in accordance with **Annex D-10**.

## **15. WATERPROOF TEST**

### **15.1 General**

**15.1.1** The waterproof test is conducted to determine the effectiveness of the seals of the power tiller when operated under lowland condition.

**15.1.2** The power tiller shall be fitted with puddling wheels as per recommendation of manufacturer and with no implement attached.

**15.1.3** The power tiller is classed as “waterproof power tiller,” if after the test described below, there is no water penetration into axle, brake and clutch system (4.9.1 OECD Code 2-2018).

## **15.2 Test Conditions**

### **15.2.1 Test Bed**

The test shall be conducted in a testing water bath/cistern filled with water (OECD Code 2-2018)

### **15.2.2 Water Level**

The water level shall be adjusted to the height of the centre line of the wheel axle with the power tiller in a horizontal position. The power tiller shall be installed and fixed on a stand for free rotation of puddling wheels.

## **15.3 Test Procedures**

### **15.3.1. General Provisions**

**15.3.1.1** The power tiller shall be in the gear giving the nominal forward speed nearest to 6 km/h (4.9.3.1 OECD Code 2-2018) and operated continuously at rated engine speed for 5 hour.

**15.3.1.2** If there is leakage of oil from the axle shaft to water prior to the completion of test, then the test shall be terminated.

**15.3.1.3** The power tiller shall then be removed from the testing bath and be cleaned.

**15.3.1.4** The power tiller shall be left in a place free from rain or snow for at least 12 hour before being finally checked (4.9.3.1 OECD Code 2-2018).

**15.3.1.5** The axle and gearbox shall then be disassembled and any evidence of water penetration into them shall be stated in the test report.

### **15.3.2 Unsuccessful Test**

If the test fails, the manufacturer may ask for a repeat test of the same power tiller but only once. The power tiller when re-tested shall be equipped with the same components after the seals have been changed and/or re-fixed in conformity with manufacturer’s specifications (4.9.3.2 OECD Code 2-2018).

### **15.3.3 Checking Methods for Ingress of Water in the Oil**

The oil in the housing (e. g. gearbox, engine sump) shall be checked using one or more of the following alternative methods (4.9.3.3.2 OECD Code 2-2018).

**15.3.3.1** Visual method: Distinct emulsification and/or colour change of the oil shall be regarded as proof of water ingress or;

**15.3.3.2** Crackling method: When water ingress is not visually distinct, the presence of water in the lubricant shall be checked by putting a heated electric soldering iron into the oil. The presence of water crackling shall be regarded as waterproof failure; conversely, no crackling shall be regarded as waterproofing; or

**15.3.3.3** Other methods: Other physical (e.g. centrifugation) or chemical (e.g. Karl-Fisher) standards to check if there is water in the oil.

The data shall be recorded in **Annex D-11**.



## **16. SAFETY REQUIREMENTS**

### **16.1 Guards (IS 12239-3:1988)**

All hot and dangerous parts shall be guarded or so located that they are safe enough.

Provision of the safety guard which shall not allow the operator's hand, feet and clothing to approach moving parts in normal working conditions, shall be made.

### **16.2 Controls (IS 12239-3:1988)**

16.2.1 Moving parts, pinching points or sharp edge control surfaces are to be effectively shielded or covered with protective material to prevent injury to the operator/workers.

16.2.2 The location of hand controls which determines the position of the operator relative to the power tiller, and working parts of the tiller should be designed to prevent accidental contact of operator with such dangerous parts.

16.2.3 All controls shall be identifiable by symbols and displays.

16.2.4 Provision shall be made to protect controls by means of locking device or by location, to prevent accidental operation which may cause dangerous movement. The rotary device shall not rotate when the power tiller is operated in reverse gear to protect the operator's feet from injury.

16.2.5 Engine of the power tiller shall be provided with a device to enable it to stop immediately. A clutch device may be provided to disengage the rotary device instantaneously. This should be easily accessible to the operator in his/her working position. These shall be so designed that they do not depend on sustained manual effort for their operation and also when they are in stop position. Method of operation shall be clearly indicated on the power tiller.

### **16.3 Working Stability (IS 12239-3:1988)**

A retractable ground stand shall be provided which could be easily deployed to arrest over-turning when parking the power tiller. Provision to prevent accidental retraction of the stand shall be made.

### **16.4 Lighting (IS 12239-3:1988)**

For safe operation during night and on highway, effective lighting provision shall be made.

At least a single head-lamp shall be mounted on the front or above the engine of the power tiller.

### **16.5 Power Transmission (IS 12239-3:1988)**

16.5.1 Power take-off shaft - If provided, it shall be protected by means of a non-rotating cover or casing which covers the PTO completely and is attached to the body of the tiller.

16.5.2 Rotary tiller - When rotary tiller or other attachment with the power tiller is provided, it should be enclosed in a non-rotating casing. This should be so designed as to prevent accidental contact of any part of the operator's body with rotating/cutting parts. Casing so provided should be adjustable so that access is provided for assembly and maintenance of rotary device.

### **16.6 Other Requirements (IS 12239-3:1988)**

16.6.1 The operator should be protected from effects of tillage device on the soil by means of a shield, wherever possible, including mudguards on wheels.

16.6.2 The outlet of the exhaust pipe shall be located and directed in such a way that the operator

will not normally be exposed to harmful concentrations of noxious gases or fumes.

16.6.3 The power tiller is to be equipped with brakes which can stop the tiller under all manufacturer's recommended operating conditions.

**16.7 Operational Safety Requirements (IS 12239-3:1988)**

All routine checks and maintenance schedules as indicated by the manufacturer, are to be clearly understood by the operator before operating the power tiller.

The observations shall be recorded in **Annex E**

## ANNEX A: LIST OF CITED STANDARDS

<b>Standards No.</b>	<b>Title</b>
ANTAM 001-2016	Asian and Pacific Network for Testing of Agricultural Machinery Standard Code for Testing of Power Tillers
GB/T 6229-2007	Test Methods for Walking Tractors
IEC 60651-1979	Sound Level Meters
IS 12036:1995	Agricultural Tractors-Test Procedures-Power Test for Power Take-off
IS 12180-1:2000	Tractors and Machinery for Agriculture and Forestry-- Noise Measurement- Method of Test: Part: 1: Noise at the Operator's Position - Survey Method
IS 12180-2:2000	Tractors and Machinery for Agriculture and Forestry-- Noise Measurement- Method of Test: Part: 2: Noise Emitted when in motion
IS 9935:2002	Power Tiller -- Test Codes
IS 12239-3:1988	Guide for Safety and Comfort of Operator of Agricultural Tractors and Power Tillers: Part 3: Requirements Relating to Power Tillers
ISO 4251-1:2017	Tyres (Ply Rating Marked Series) and Rims for Agricultural Tractors and Machines -- Part 1: Tyre Designation and Dimensions, and Approved Rim Contour
ISO 5353:1995	Earth-Moving Machinery and Tractors and Machinery for Agriculture and Forestry -- Seat Index Point
ISO 5131:1996	Tractors and Machinery for Agriculture and Forestry- Measurement of Noise at the Operator's Position- Survey Method
OECD Code 2-2018	OECD Standard Code for the Official Testing of Agricultural and Forestry Tractor Performance

*ANTAM = Asian and Pacific Network for Testing of Agricultural Machinery*

*IS = Indian Standards*

*GB/T and JB/T = Chinese Standards*

*IEC = International Electrotechnical Commission*

*ISO = International Organization for Standardization*

*OECD = Organization for Economic Co-operation and Development*

## **ANNEX B: PROFORMA FOR SELECTION, RUNNING-IN AND REPAIRS**

**B-1 Name of the manufacturer**

**B-2 Address**

**B-3 Submitted for test by**

**B-4 Selected by**

**B-5 Place of running-in**

**B-6 Duration and schedule of running-in**

**B-7 Repairs and adjustments made during running-in**

**B-8 Number of sealing**

**B-9 Location of sealing**

## ANNEX C: SPECIFICATION SHEET FOR POWER TILLERS

<p><b>C-1 POWER TILLER</b></p> <p>a) Name and address of the manufacturer:  b) Name and address of the applicant for test:  c) Type:  d) Make/Model:  e) Serial number:  f) Year of manufacturing:  g) Net mass (kg):</p>
<p><b>C-2 ENGINE</b></p> <p>a) Type/Make/Model:  b) Name and address of the manufacturer:  c) Serial number:  d) Engine rated speed (recommended by manufacturer):  e) Power at rated speed (kW):  f) Net mass (kg):</p>
<p><b>C-3 CYLINDER AND CYLINDER HEAD</b></p> <p>a) Configuration (vertical or horizontal):  b) Bore/stroke (mm):  c) Capacity (cm<sup>3</sup>):  d) Compression ratio:  e) Type of combustion chamber:</p>
<p><b>C-4 FUEL SYSTEM</b></p> <p>a) Type of fuel  b) Capacity of fuel tank (l):  c) Type of fuel filter:  d) Manufacturer's production setting of fuel injectors (Valve opening pressure) (kPa):  e) Injection timing:  f) Type of injection pump:</p>
<p><b>C-5 GOVERNOR</b></p> <p>a) Type:  b) Governed range of engine speed (rpm):  c) Rated engine speed (rpm):</p>
<p><b>C-6 AIR CLEANER</b></p> <p>a) Type (wet or dry):  b) Location of air intake (in case of no pre-cleaner):  c) Oil sump capacity (l):</p>
<p><b>C-7 EXHAUST</b></p> <p>a) Type of silencer:  b) Location:</p>

**C-8 LUBRICATING SYSTEM**

- a) Type:
- b) Oil sump capacity (l):

**C-9 COOLING SYSTEM**

- a) Type:
- b) Details of pump and fan, if available:
- c) Coolant capacity (l):

**C-10 ELECTRICAL SYSTEM**

- a) Voltage:
- b) Output power of generator (W):
- c) Details of headlights (number, W):

**C-11 POWER TRANSMISSION SYSTEM**

- a) Gearbox
  - 1) Oil capacity (l):
  - 2) Grade of oil:
  - 3) Number of gears
    - i) Forward:
    - ii) Reverse:
  - 4) Nominal traveling speed at rated engine speed

	Gear number	Nominal traveling speed (*) at the rated engine speed of ... rpm (km/h)
Forward	L1	
	L2	
	L3	
	H1	
	H2	
	H3	
Reverse	L	
	H	

\* Calculated with a pneumatic tyre dynamic radius index of ..... mm  
(ISO 4251-1:2017)

- b) Type of main clutch:
- c) Type of steering clutch:

**C-12 ROTARY SHAFT (If applicable)**

- a) Location:
- b) Number of splines:
- c) Speed (rpm):
- d) Diameter of shaft (mm):
- e) Height above ground (mm):
- f) Direction of rotation (viewed from driving end):
- g) Rotary shaft speed at rated engine speed (rpm):
- h) Power transmission system
  - 1) Sprocket and chain:
  - 2) Any other:
- i) Arrangement for fitting of tynes on the shaft:
- j) Number and type of tynes:

**C-13 MAIN PULLEY**

- a) Type and number of belts:
- b) Diameter (mm):
- c) Location:
- d) Reduction ratio (from engine to clutch):
- e) Rotational speed at rated engine speed (rpm):

**C-14 HITCH (If applicable)**

- a) Type (pin or nut and bolt):
- b) Location:
- c) Height above ground level (mm)
  - 1) Maximum:
  - 2) Minimum:

**C-15 PARKING BRAKE**

- a) Type:
- b) Method of operation:

**C-16 WHEEL**

- a) Pneumatic Tyres
  - 1) Make:
  - 2) Size:
  - 3) Type of tyre:
  - 4) Ply rating:
  - 5) Recommended inflation pressure (kPa)
    - i) For field work:
    - ii) For transport:
  - 6) Track width (mm):
  - 7) Method of changing track width, range and number of steps:
  - 8) Method of changing track width, if any, and range:
- b) Steel wheel for wet land
  - 1) Track width (mm):
  - 2) Type:
  - 3) Size
    - i) Diameter (mm):
    - ii) Width (mm):
  - 4) Number of lugs:
  - 5) Total mass (two wheels) (kg):
- c) Tail wheel (if applicable)
  - 1) Steel wheel
    - i) Diameter (mm):
    - ii) Width (mm):
    - iii) Mass (kg):
  - 2) Pneumatic tyre
    - i) Type:
    - ii) Tyre inflation (kPa):
    - iii) Mass (kg):

**C-17 OPERATOR'S SEAT FOR RIDING TYPE**

- a) Type:
- b) Type of suspension:
- c) Range of adjustment (if any) (mm):

<b>C-18 MASS OF BALLAST</b>				
Ballast Mass as Used (kg)				
	Water		Cast Iron Weight on Wheel	
Optional ballast				
<b>C-19 MASS OF POWER TILLER (kg)</b> (without driver but with lubricant, fuel and coolant full)				
	Ballast		Un-ballast	
Total				
<b>C-20 OVERALL DIMENSIONS (mm)</b>				
Conditions	Length*	Width*	Height*	Ground Clearance
With ballast				
Without ballast				
* Measure at the outermost points				



## ANNEX D: DATA SHEET FOR LABORATORY AND TRACK TESTS OF POWER TILLER

<p><b>D-1 POWER TEST</b></p> <p>a) Date and place of test:            b) Type of dynamometer used:            c) Fuel used                1) Type:                2) Density at 15 °C:            d) Engine oil used                1) Type:                2) Grade:            e) Transmission oil used:            f) No load maximum engine speed (rpm):            g) Engine performance test data are given in <b>D-6</b>:</p>		
<p><b>D-2 ROTARY SHAFT TEST</b></p> <p>a) Date and place of test:            b) Type of dynamometer used:            c) Fuel used                1) Type:                2) Density at 15 °C :            d) Engine oil used                1) Type:                2) Grade:            e) Type of transmission oil used:            f) No load maximum engine speed (rpm):            g) Engine performance test data sheet given in <b>D-6</b>:</p>		
<p><b>D-3 DRAWBAR PERFORMANCE TEST</b></p> <p>a) Date and location of tests:            b) Type of track:            c) Height of drawbar point above ground (mm):            d) Mass of power tiller, without ballast (kg):            e) Type and size of tyres:            f) Tyre pressure (kPa):            g) Details of fuel used (fuel number and standard):            h) Test data (see <b>D-8</b>):</p>		
<p><b>D-4 TURNING ABILITY</b></p> <p>a) Details of pneumatic wheels                1) Wheel track (mm):                2) Size of tyres:                3) Pressure of tyres (kPa):            b) Test data</p>		
Description	Minimum Turning Circle Diameter	Minimum Turning Space Diameter

	Right Hand Side (m)	Left Hand Side (m)	Right Hand Side (m)	Left Hand Side (m)
(1)	(2)	(3)	(4)	(5)
With Steering Clutch				
<b>D-5 PARKING BRAKE TEST</b>				
Power tiller mass (kg):				
Degree of slope (degree):				
Observations	Parking Brake Device Facing up Slope		Parking Brake Device Facing down Slope	
(1)	(2)		(3)	
Parking brake device control force (N)				
Whether rolling of braking wheels noticed	Yes/No		Yes/No	
Efficacy of brakes	Yes/No		Yes/No	

<b>D-6 ENGINE PERFORMANCE TEST DATA SHEET</b>														
Test	Power (kW)	Crank Shaft Torque (Nm)	Engine Speed (rpm)	Fuel Consumption		Specific Energy (kWh/l)	Temperature (°C)					Atmospheric Conditions		
				Hourly (kg/h)	Specific (g/kWh)		Fuel	Intake air	Engine oil	Coolant	Exhaust air	Temp (°C)	Relative Humidity (%)	Pressure (kPa)
(1)	(2)	(3)	(4)	(5)	(6)	(7)	(8)	(9)	(10)	(11)	(12)	(13)	(14)	(15)
<b>1. Natural Ambient</b>														
i) Maximum power test														
ii) Power at rated engine speed														
Varying engine speed at full load i) ii) iii) iv) v) vi)														
Rated engine speed at varying load i) ii) iii) iv) v) vi)														
<b>2. High Ambient (Optional)</b>														
i) Maximum power test absolute i) ii) iii)														

ii) Maximum power at rated engine speed i) ii) iii)																			
i) Varying speed at full load i) ii) iii) etc																			

- a) Coolant consumption (l/kWh):
- b) Specific lubricating oil consumption (g/kWh):

FIVE HOURS TEST												
Test	Power (kW)	Crank Shaft Torque (Nm)	Engine Speed (rpm)	Fuel Consumption		Specific Energy (kWh/l)	Temperature (°C)			Atmospheric Conditions		
				Hourly (kg/h)	Specific (g/kWh)		Fuel	Engine oil	Coolant	Temp (°C)	Relative Humidity (%)	Pressure (kPa)
(1)	(2)	(3)	(4)	(5)	(6)	(7)	(8)	(9)	(10)	(11)	(12)	(13)
Five hours engine rating test a) At load corresponding to 90% of maximum power (4 hour) i) ii) iii) etc.												
At load corresponding to maximum power i) ii) iii)												

**D-7 ROTARY SHAFT PERFORMANCE TEST DATA SHEET**

Sl. No.	Test Condition	Tests	Rotary Shaft Power (kW)	Rotary Shaft Torque (Nm)	Engine Speed rpm	Fuel Consumption		Specific Energy (kWh/l)	Temperature (°C)						Pressure (kPa)			Atmospheric Conditions		
						Hourly (g/h)	Specific (g/kWh)		Fuel	Engine Oil	Exhaust	Intake Air	Coolant	Rotary Shaft Oil Temp	Intake Air	Exhaust Gas	Lub Oil	Temp (°C)	Relative Humidity (%)	Pressure (kPa)
						(7)	(8)	(9)	(10)	(11)	(12)	(13)	(14)	(15)	(16)	(17)	(18)	(19)	(20)	(21)
(1)	(2)	(3)	(4)	(5)	(6)	(7)	(8)	(9)	(10)	(11)	(12)	(13)	(14)	(15)	(16)	(17)	(18)	(19)	(20)	(21)

i)	Normal Ambient Test	Varying engine speed at full load i) ii) iii) etc																	
	same	Five hours test at rated power of rotary shaft a) At load corresponding to 90 % of maximum power (4 hours): i) ii) iii) etc b) At load corresponding to maximum power i) ii) iii)																	

<b>D-8 TEST DATA FOR DRAWBAR PERFORMANCE</b>												
Test	Gear Number Used	Travel Speed (km/h)	Drawbar Pull (kN)	Drawbar Power (kW)	Wheel Slip (%)	Engine Speed (rpm)	Fuel Consumption		Specific Energy (kWh/1)	Atmospheric Conditions		
							kg/h	g/kWh		Temperature (°C)	Pressure (kPa)	Relative Humidity (%)
(1)	(2)	(3)	(4)	(5)	(6)	(7)	(8)	(9)	(10)	(11)	(12)	(13)
Maximum power test												

(power tiller un-ballasted)												
i)												
ii)												
iii)												

**D-9 DATA SHEET FOR NOISE MEASUREMENT**

<b>MEASUREMENT POSITION</b>				<b>Operator Ear Level</b>	<b>By-stander</b>	
<b>D-9.1 Brief Description of the Silencing System</b>						
<b>D-9.2 Sound Level Meter</b> 1) Type: 2) Make: 3) Model:						
<b>D-9.3 Date of Test</b>						
<b>D-9.4 Background Noise Level, dB(A)</b>						
<b>D-9.5 Atmospheric Conditions</b> a) Temperature (°C) b) Wind velocity (m/s) c) Pressure (kPa) d) Relative humidity (%)						
<b>D-9.6 Test Data for Operator Ear Level</b>						
No.	Gear Used	Travelling Speed (km/h)	Engine Speed (rpm)	Slip (%)	Drawbar Pull (kN)	Sound Level (dB(A))
(1)	(2)	(3)	(4)	(5)	(6)	(7)
1						
2						
3						
4						
5						
6						

**D-9.7 Test Data for By-stander Position**

S. No.	Gear Used	Engine Speed (rpm)	Noise Level (dB(A))

**D-9.8 Test Data for Octave Band Noise Level Measurement at By-stander Position (Optional)**

S. No.	Gear Used	Engine Speed (rpm)	Sound Pressure Level (dB)								
			Centre Frequency (Hz)								
			31.5	63	125	250	500	1000	2000	4000	8000



**D-10 TEST DATA FOR VIBRATION MEASUREMENT**

D-10.1 Date of test

D-10.2 Type of instrument

D-10.3 Location of test

D-10.4 Type of power tiller (tilling or pull)

S. No.	Measuring points		Acceleration (m/s <sup>2</sup> )	
			HD	VD
			1	Steering handle
		Right arm grip		
2	Operator's seat (without operator)			
3	At main frame where engine is mounted			

\* HD: Horizontal direction

VD: Vertical direction

**D-11 DATA SHEET FOR WATERPROOF TEST**

Sr. No.	Components	Ingress of Water
1	Axle	Yes/No
2	Gearbox	Yes/No

## ANNEX E: PROFORMA FOR SAFETY CHECK

### E1-Guards

S. No.	Moving Parts	Guarded or Safely Located
1	PTO shaft	Yes/No
2	Main pulleys	Yes/No
3	Flywheel	Yes/No
4	Rotary chains	Yes/No
5	Belts	Yes/No
6	Rotary tiller	Yes/No

S. No.	Hot Parts	Guarded or Safely Located
1	Exhaust silencer	Yes/No
2	Exhaust manifold	Yes/No
3	Any others	Yes/No

### E-2 Controls

S. No.	Controls	Identifiable or Displayed
1	Clutch lever	Yes/No
2	Brake lever	Yes/No
3	Throttle lever	Yes/No
4	Lever to stop engine immediately	Yes/No
5	Main gear shifting lever	Yes/No
6	High/low gear shifting lever	Yes/No
7	Rotary engaging lever	Yes/No
8	Steering handle with side clutch lever	Yes/No
9	Tail wheel height adjusting lever	Yes/No

### E-3 Working Stability

Is ground stand of power tiller retractable? Yes/No

### E-4 Lighting

Is head light available in the power tiller? Yes/No

### E-5 Power Transmission

Is power take-off (if provided) available with guard? Yes/No

Is rotary tiller available with guard or cover? Yes/No

### E-6 Other Observations, if any

## Appendix I: ANTAM Focal Points (As of September 2018)

### **1. Armenia**

Mr. Armen Harutyunyan  
Adviser  
Minister of Agriculture of the Republic of Armenia

E-mail: armenharut@gmail.com

### **2. Bangladesh**

Mr. Sheikh Md Nazimuddin  
Project Director  
Farm Mechanization Project  
Department of Agricultural Extension

E-mail: nazimdae@gmail.com

### **3. Cambodia**

Dr. Chan Saruth  
Director  
Department of Agricultural Engineering  
Ministry of Agriculture, Forestry and Fisheries

E-mail: saruthchan@hotmail.com

### **4. China**

Ms. Han Xue  
Deputy Division Director  
Division of Technology & Foreign Affairs  
China Agricultural Machinery Testing Center (CAMTC)  
Ministry of Agriculture of the People's Republic of China

E-mail: hanxue100@foxmail.com

### **5. France**

Dr. Jean-Paul Douzals  
Researcher  
National Institute of Science and Technology for  
the Environment and Agriculture (IRSTEA)

E-mail: jean-paul.douzals@irstea.fr

### **6. Hong Kong, China**

Ms. Mandy Au  
Regional Cooperation Division Trade and Industry Department

E-mail: mandyau@tid.gov.hk

### **7. India**

Dr. Karuppiah Alagusundaram  
Deputy Director General (Engineering)  
Indian Council of Agricultural Research (ICAR)

E-mail: ddgengg@icar.org.in

### **8. Indonesia**

Dr. Astu Unadi  
Senior Researcher  
Indonesian Centre for Agricultural Engineering Research and Development (ICAERD)  
Indonesian Agency for Agricultural Research and Development (IAARD)  
Ministry of Agriculture

E-mail: unadiastu@yahoo.com

### **9. Japan**

Mr. Hiroshi Fujimura  
Director General  
Institute of Agricultural Machinery (IAM)  
National Agriculture and Food Research Organization (NARO)

E-mail: hfjmr@affrc.go.jp

### **10. Malaysia**

Mr. Mohd Taufik Bin Ahmad  
Senior Research Officer  
Engineering Research Centre  
Malaysian Agricultural Research and Development Institute (MARDI)

E-mail: taufik@mardi.gov.my

### **11. Nepal**

Mr. Ishwori Prasad Upadhayay  
Division Chief  
Agricultural Engineering Division  
Nepal Agricultural Research Council

E-mail: ishwaripu@yahoo.com

### **12. Pakistan**

Dr. Tanveer Ahmad  
Director and Principal Engineer  
Agricultural and Biological Engineering Institute National Agricultural Research Centre  
(NARC)

E-mail: tanveerz\_isd@yahoo.com

### **13. Philippines**

Dr. Aurelio A. Delos Reyes

Director  
Agricultural Machinery Testing and Evaluation Center (AMTEC)  
College of Engineering and Agro-Industrial Technology

E-mail: aadelosreyes2@up.edu.ph

**14. Republic of Korea**

Dr. Young-lim Kim  
Action Officer  
Agro-material Industry Division,  
Rural Development Administration  
Ministry of Agriculture, Food and Rural Affairs

E-mail: tree70@korea.kr

**15. Russia**

Dr. Vadim Pronin  
Chairman  
Executive Board  
Association of Testing of Agriculture Machinery and Technology

E-mail: vadim\_pronin@mail.ru

**16. Sri Lanka**

Mr. B. M. Chintaka P. Balasooriya  
Deputy Director  
Farm Mechanization Research Centre  
Department of Agriculture

E-mail: chinthaka.balasooriya@gmail.com

**17. Thailand**

Mr. Viboon Thepent  
Senior Agricultural Engineering Specialist  
Agricultural Engineering Research Institute  
Department of Agriculture  
Ministry of Agriculture and Cooperatives

E-mail: v\_thepent@hotmail.com

**18. Turkey**

Mr. Duran Doganguzel  
Agricultural Engineer  
Directorate of Testing Center of Agricultural Equipment and Machine  
Ministry of Food Agriculture and Livestock

Email: duran.doganguzel@tarim.gov.tr

**19. Vietnam**

Mr. Tran Duc Tuan  
Deputy Director  
Research Centre for Agricultural Machinery and Aero-Hydraulic  
Vietnam Institute of Agricultural Engineering and Post-Harvest Technology

E-mail: [Ductuanvcd@gmail.com](mailto:Ductuanvcd@gmail.com)

## Appendix II: ANTAM Technical Working Groups Members 2018

### Technical Working Group on Power Tillers

<b>Name</b>	<b>Country</b>
Dr. Israil Hossain	Bangladesh
Dr. Chhoeur Sothunn	Cambodia
Mr. Chang Xiongbo	China
Dr. Champat Raj Mehta	India
Mr. Muhamad Iqbal	Indonesia
Dr. Dr. Takahashi HiroyukiTakahashi Hiroyuki	Japan
Mr. Mohd Khusairy Khadzir	Malaysia
Mr. Liaqat Ali Shahid	Pakistan
Mr. Darwin Aranguren	Philippines
Dr. Vadim Pronin	Russia
Mr. Janaka Hemachandra	Sri Lanka
Dr. Anuchit Chamsing	Thailand
Mr. Le Huy Phuong	Vietnam

### Technical Working Group on Powered Knapsack Misters-Cum-Dusters

<b>Name</b>	<b>Country</b>
Mr. Duc Sam On	Cambodia
Ms. Ma Lingjuan	China
Dr. Douzals Jean-Paul	France
Dr. Panna Lal Singh	India
Mr. Azmy Ulya	Indonesia
Mr. Kawase Yoshiyuki	Japan
Mr. Mohd Fazly Bin Mail	Malaysia
Dr. Hafiz Sultan Mahmood	Pakistan
Mr. Pavel Ishkin	Russia

Ms. Ayesha Herath	Sri Lanka
Ms. Khanit Wannaronk	Thailand
Mr. Baris Ozgur Kocturk	Turkey
Mr. Nguyen Tuan Anh	Vietnam

### Technical Working Group on Paddy Transplanters

<b>Name</b>	<b>Country</b>
Dr. Md. Anwar Hossen	Bangladesh
Mr. Zhang Xiaochen	China
Dr. Allimuthu Surendrakumar	India
Mr. Takashi Fujimori	Japan
Mr. Mohd Shahril Shah bin Mohamad Ghazali	Malaysia
Dr. Shabbir Ahmad Kalwar	Pakistan
Mr. Romulo Esteban Eusebio	Philippines
Mr. Jeong Seong im	Republic of Korea
Mr. Anuradha Wijethunga	Sri Lanka
Dr. Yuttana Khaehanchanpong	Thailand
Mr. Ngo Van Phuong	Vietnam





United Nations  
Centre for Sustainable Agricultural Mechanization

A-7/F, China International Science and  
Technology Convention Centre  
No.12, Yumin Road, Chaoyang District  
Beijing 100029, P.R.China

Tel: (86-10) 8225 3581  
Fax: (86-10) 8225 3584  
[info@un-csam.org](mailto:info@un-csam.org)  
[www.un-csam.org](http://www.un-csam.org)

